



## RS-232/RS-485

### HC-05 Interface Converter Instruction

#### I .Summary

In order to carry through remote digital communication between computers with various standard series interfaces converter facilities or intelligent instruments, it needs inter exchange of standard series interface converter of compatible RS-232C and RS-485 standard is able to convert mono-end RS-232 signal to balance difference RS-485 signal and extend the communication distance to 1.2km. No external power but adopts a particular RS-232 charge pump to drive the system, and gains electricity without initializing the RS-232 series interface. An internal zero delay auto transceiver and particular I/O circuit automatically control the data stream direction in stead of an handshake signal (for example RTS,DTR etc).There by in guarantees the function under RS-485 without changing the program compiled under RS-232 half-duplex mode and assures the adaptation to current operation software and interface hardware. The transmission rate of 300-115.2kbps. Is capable of applying between host computers, host computer and is extensions or external equipment and forms dot to dot, dot to dots remote and multi-communication network, It implements multi-machine response communication and commonly used in systems of industrial automation control all-one-card. Door safe, car parking, ATM, bus charge, eatery sell out, staff attendance management, and toll highway etc.

#### II. Capabilities parameter

Interface feature: RS-232C, RS-485 standard interface compatible with EIA,TIA

Electric interface: RS-232 end DB9 hole connector, RS-485 end DB9 needle connector, with connection pole

Working mode: asynchronism half-duplex difference transmission

Transmission media: twisted -pair or STP

Transmission rate: 300-115.2KBPS

External discharge dimension: 63mm X33mmX17mm

Working circumstance : - 25 to 70 degree C, relative humidity 5% to 95%

Transmission distance: 1,200m (RS-485 end), 5m (RS-232 end)

### III. Connector an signal:

RS-232C bay-line distribution

DB9 Female(PIN)	RS-232C Interface Signal
1	Protective
2	RXD SIN
3	TXD SOUT
4	DTR
5	GND
6	DSR
7	RTS
8	CTS
9	RI

RS-485 data output & connector and bay-line distribution

DB9 Male(PIN)	Data Output	RS-485 Half-Duplex
1	T/R+	RS-485 (A+)
2	T/R-	RS-485 (A-)
3	RXD+	N/C
4	RXD-	N/C
5	GND	Ground Wire
6	VCC	+5V Standby Power input

### IV. Hardware installation & application

The product exterior adopts DB-9 to DB-9 all-purpose transit plugs, output plug carries ordinary connection pole, can use TP or STP and easy connection and disassembly, T/R+, T/R- stands for dispatching A+, B-, VCC stands for standby power input, GND stands for public ground wire, Point-to-point or point-to-multipoint , half-duplex communication need 2 connection (T/R+, T/R-),

connection principle is T/R+ connects to opposite T/R+, T/R- connects to opposite T/R-, RS-485 half-duplex mode connection is to connect T/R+ to opposite A+, and T/R- to opposite B-.

Remark: A+ for (485+), B- for (485-)

HC-05 interface supports 2 communication modes as below

1、 Point-to-point 2 wires half-duplex

1. RS-485 Point-to-point 2 wires half-duplex

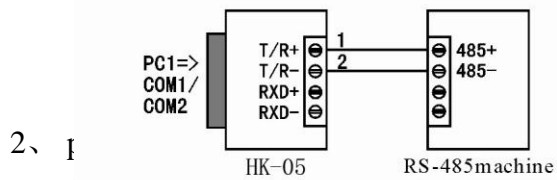

2. RS-485 point-to-multipoint 2 wires half-duplex

resist

V. C

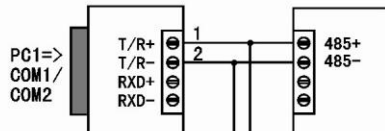

connection, it needs to install a matching terminal reflection and interference.

1. RS-485 Point-to-point 2 wires half-duplex

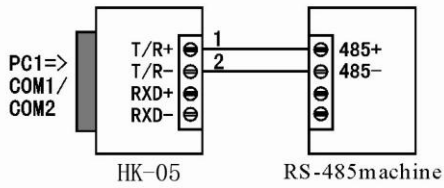

2. RS-485 point-to-multipoint 2 wires half-duplex

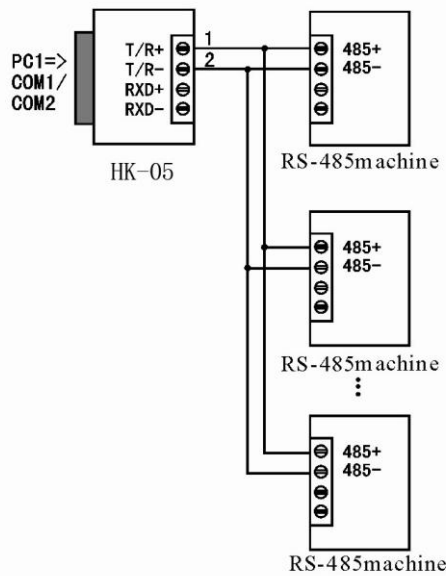

3. UT-201 half-duplex communication connect between interface converter

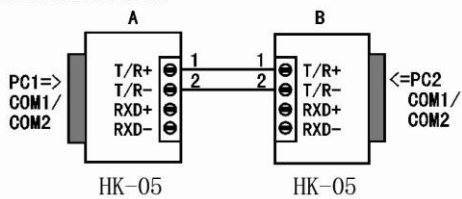

## VI. Problem and resolution

1. data communication failure

- A. Check if RS-232 interface connection is correct
- B. Check if RS-232 output connection is correct
- C. Check if connection ends are well connected

2. data loss or mistake

- A. Check if data rate and format is consistent on both communication end.